

END DRIVE

Low Profile End Drives Conveyors for all your conveyor applications where space is a premium. We have the latest in technology. We offer various sizes of conveyors featuring below, top side and direct drives. We have a wide variety of belt sizes and types for all your applications including fabric, wire mesh, cleats, timing and plastic chain.

SPECIFICATIONS

Frames:

2 7/8" high aluminum extrusion
2 7/8" high stainless steel

Conveyor Widths:

2 1/8" – 100 1/2"

Drives:

End – Direct, Top, Bottom mounted

Live Load Capacity:

Up to 50 lbs/ft.

FEATURES

- Space saving conveyor
- Design flexibility
- Belts are 1/2" less than frames
- Wide variety of belt sizes and types
- Precision machined conveyor components
- Low profile to work in tight places
- Rollers are machined tapered
- Belts are factory tracked
- Endless belts require less maintenance than metal laced belts
- Conveyors are rated for industrial environments
- Supports are modular design
- Controls are Nema 12 rated to meet factory requirements



Low Profile End Drives

APPLICATIONS

Transportation
Accumulation
Automated Part Feeding Cells
Feeder Bowl Conveyors
Sortation
Indexing
Part Orientors
Metering Conveyors
Assembly Lines
Work Stations
Cooling



End Drive

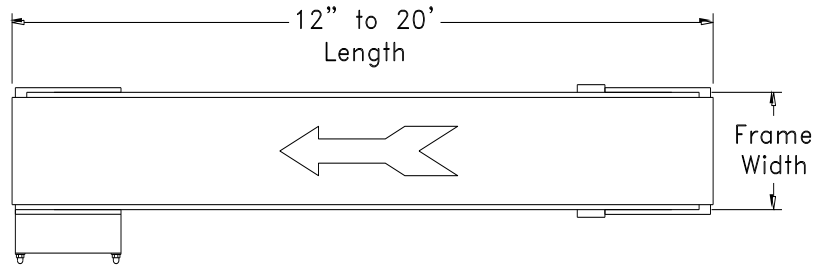
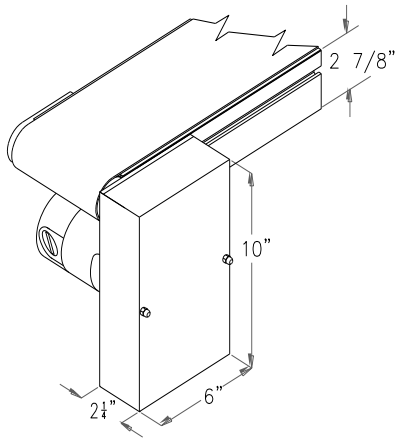

Plan View



Side View

Standard Sizes

Frame Width	Belt Width
2 1/8"	1 5/8"
4 1/2"	4"
6 1/2"	6"
8 1/2"	8"
10 1/2"	10"
12 1/2"	12"
14 1/2"	14"
16 1/2"	16"
18 1/2"	18"
20 1/2"	20"
22 1/2"	22"
24 1/2"	24"

