

Guide rail components

Contents

System information.....	303	Bracket support components, Zinc.....	319
Track width calculations.....	304	Spacers.....	319
Examples.....	306	Guide rail clamp supports.....	320
Configuration examples.....	307	Guide rail clamps.....	321
Circular guide rails.....	309	Accessories.....	322
Guide rails 10 mm.....	309	Guide rails system X45, X45H and X65.....	323
Guide rails 15 mm.....	310	Width adjustment.....	323
Guide rail bending machine.....	310	Using Guide rail cover.....	324
Connecting sleeve.....	311	Straight guide rails.....	324
Flexible roller module.....	311	Connecting strips.....	324
Guide discs.....	312	Guide rail bracket for X45.....	325
Fixed guide rail brackets.....	313	Guide rail bracket for X65 and X45H.....	325
Adjustable guide rail brackets, aluminium.....	315	Built-up guide rail brackets.....	326
Fixed guide rail brackets, polyamide.....	317	Guide rail system for easy adjustment of track width.....	327
Bracket support components, polyamide.....	317	Automatic guiding system components.....	329

System information



Guide rail components

Guide rails are used to guide the products being conveyed and also to prevent them from falling off the conveyor. The conveyor system includes a versatile system of *guide rails* and *guide rail brackets* which make it possible to accommodate many different product sizes and shapes. Guide rail brackets are available in fixed or adjustable configurations.

Most guide rail components in this catalogue section can be used with any of the sizes XS, X45 H, X65, X85, XH, XK, X180/X300 and WL.

Note however that the distance from the T-slot in the conveyor beam to the top of chain (TOC) varies between conveyor platforms and with the chain selection. Special guide rail systems are used for the X65, X85 and XK pallet systems.

Note

Mounting hardware for guide rail brackets etc. must be ordered separately, unless otherwise noted.

Adjustable guide rail components

The guide rail components assortment includes several adjustable guide rail bracket components which allow manual width adjustment without the use of tools, for reduced setup time. A guide rail system for automatic adjustment of the track width has been developed. See page 327.



Distance between brackets

The distance between guide rail brackets depends on the side forces to be expected, and on the guide rail type and material. In buffer conveyors with side forces, much shorter distances between brackets are required than in non-buffering applications. The distance should be somewhere between 0,3 m and 1,5 m.

Track width calculations

Basic parameters

The calculations of resulting track width require insertion of values for beam width W_B and spacer width A . See Tables 1 and 2. A is the sum of all spacers on one side.

Table 1. Beam width

System	W_B mm
X45H	45
XS	45
X65	65
X85	85
XH, XK	105
X180/X300	182/300

Table 2. Spacer width

Spacer	mm
XLRD 6 A	6
XLRD 18 A	18
XLRD 3 D	3
XLRD 6 K	6
XLRN 3	Custom width
XLRN 3 U	Custom width

Parameters W_B and A

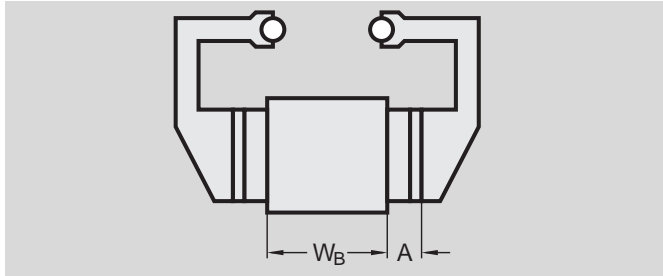

Using guide rail bracket support XLRF 42x18 V/VD

The following formula can be used to calculate the track width for a specific symmetrical combination of supports, clamps, and guide rails. For W_B and A : see Tables 1 and 2 in "Basic parameters", page 304. For parameter B : see Tables 3 and 4.

$$W = W_B + 2A + 80 - 2B$$

Table 3. Parameter B when using support type XLRF 42x18 V/VD and XLRK/XLRL guide rail clamps

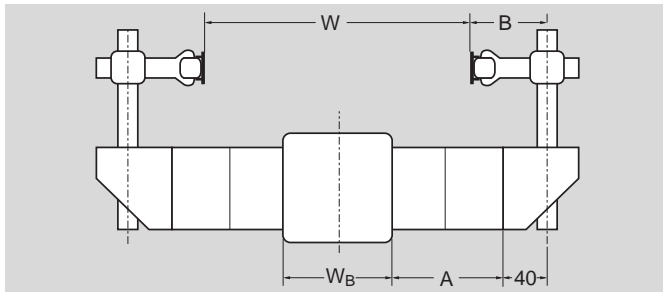

Guide rail	10 mm	15 mm	15+2 mm	18 mm
B mm	B mm	B mm	B mm	B mm
XLRK 18x40 C	41-55	46-60	48-62	42-56

Guide rail	10 mm	15 mm	15+2 mm	18 mm
B mm	B mm	B mm	B mm	B mm
XLRK 18x60 C	41-75	46-80	48-82	42-76
XLRK 18x80 C	41-95	46-100	48-102	42-96
XLRL 18x110 C	21	26	28	22
XLRK 18 CE	57-	62-	64-	58-

Note

The illustration shows a design with vertical 18 mm tube and cross connector XLRX 18 X. An alternative is to use guide rail clamp support Type CA (XLRL 18x... CA). The B values are the same.

Clamp type XLRK 18 CE is used in combination with a piece of horizontal 18 mm tube XLRR ...x18 C.

Table 4. Parameter B when using support type XLRF 42x18 V/VD and quick release guide rail clamp support XLRL 18x97 CQ

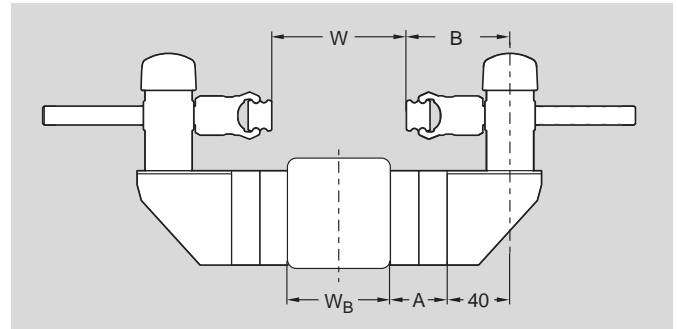

Guide rail	10 mm	15 mm	15+2 mm	18 mm	12 mm
B mm	B mm	B mm	B mm	B mm	B mm
5051168/ 5050986 + XLRK 12 CE	62-121	67-126	69-128	63-122	-
5051168/ 5050986 + XLRK 12 DE	-	-	-	-	59-118 *

*Suitable for stainless steel applications.

Note.

Guide rail clamp XLRK 12x100 D69 cannot be used with the quick release guide rail clamp support.

**Using guide rail bracket support
XLRF 42x62 A35/110**

The following formula can be used to calculate the track width for a specific symmetrical combination of supports, clamps, and guide rails (see illustrations). For W_B and A: see Table 1 and 2. For parameter B: see Table 5.

$$W = W_B + 2A + 84 - 2B$$

Table 5. Parameter B when using support type XLRF 42x62 A35/110

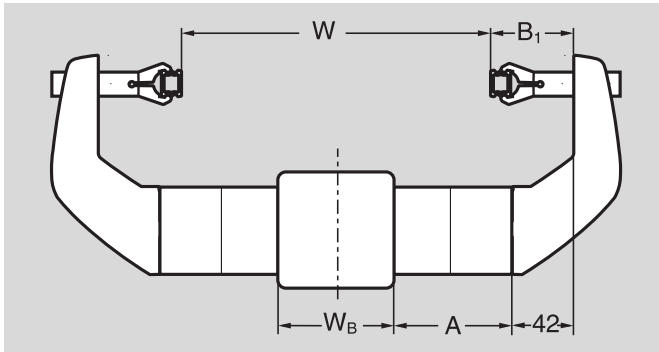

Guide rail	10 mm B mm	15 mm B mm	15+2 mm B mm	18 mm B mm
XLRK 18x40 C	28-43	33-48	35-50	28-43
XLRK 18x60 C	28-63	33-68	35-70	28-63
XLRK 18x80 C	28-83	33-88	35-90	28-83
XLRK 18 CE	44-	49-	51-	45-

Note

The maximum B value for XLRK 18x40/60/80 C applies to the guide rail clamp installed at the top level. At lower levels the maximum B value is up to 5 mm smaller.

The lowest level of XLRF 42x62 A35/110 cannot be used in an X180 conveyor for track widths smaller than 170 mm.

XLRK 18 CE is used in combination with 18 mm tube XLRR ...x18 C.

Using guide rail bracket support XLRF 30x71 K

The following formula can be used to calculate the track width for a specific symmetrical combination of supports, clamps, and guide rails. For W_B and A: see Table 1 and 2. For parameter B: see Table 6.

$$W = W_B + 2A + 90 - 2B$$

Table 6. Parameter B when using support type XLRF 30x71 K

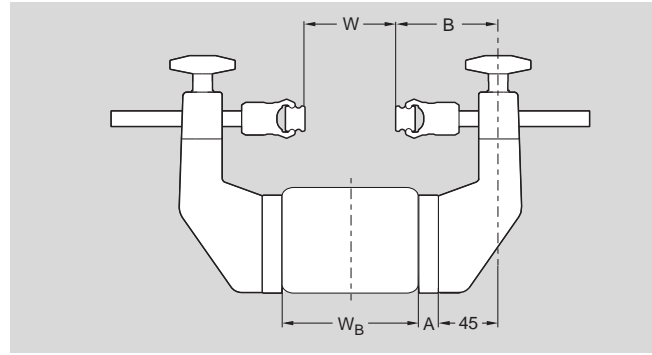

Guide rail	10 mm B mm	15 mm B mm	15+2 mm B mm	18 mm B mm	12 mm B mm	5050902 A B mm
XLRK 12 CE + 5050986	59-126	64-131	66-133	60-127	-	-
XLRK 12 DE + 5050986	-	-	-	-	56-123	-
XLRK 12x100 D69	-	-	-	-	40-110	48-118
5050887 + 5050889	-	-	-	-	-	-

Suitable for stainless steel applications.

P0
CC
X45
XS
X65
X65P
X85
X85P
XH
XK
XKP
X180
X300
GR
CS
XT
HU
WL
WK
XC
XF
XD
ELV
CTL
FST
TR
APX
IDX

Examples

Fixed guide rail support



A. Guide rails with fixed guide rail brackets



B. Guide rails with fixed guide rail brackets, polyamide

Adjustable guide rail support

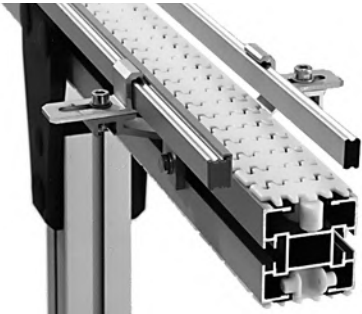

C. Guide rails with adjustable guide rail brackets, aluminium

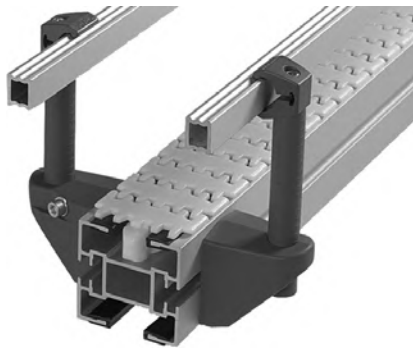

D. Guide rails with polyamide guide rail brackets adjustable in height

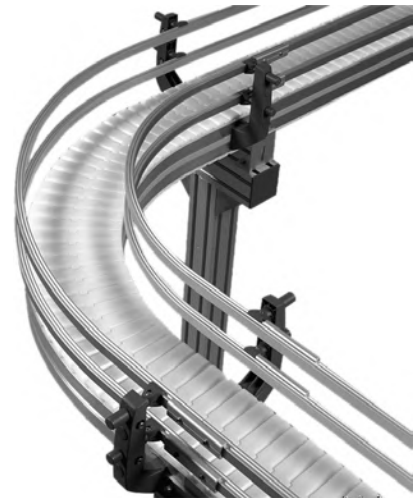

E. Guide rails at two levels with polyamide guide rail brackets, adjustable in width

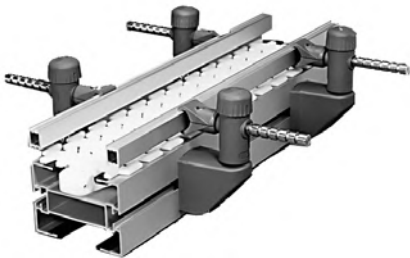

F. Guide rails with quick adjust guide rail support



G. Guide rails with built-up guide rail brackets

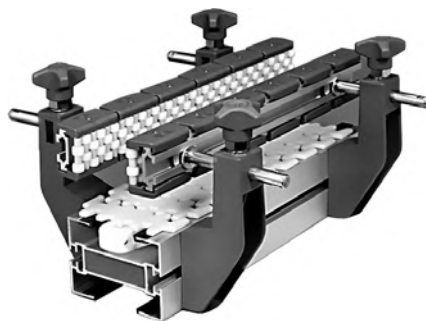

H. Roller module guide rails with polyamide guide rail brackets



I. Two-level guide rail structure with polyamide guide rail bracket components

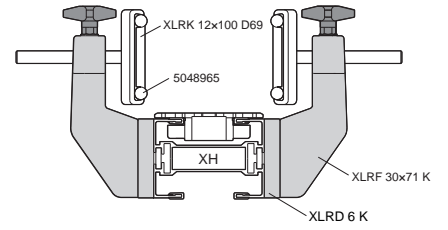
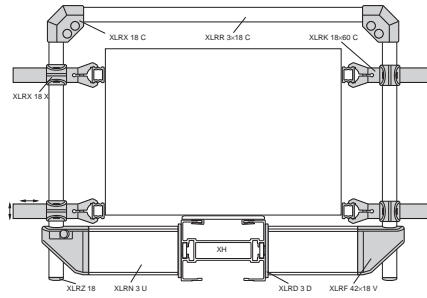
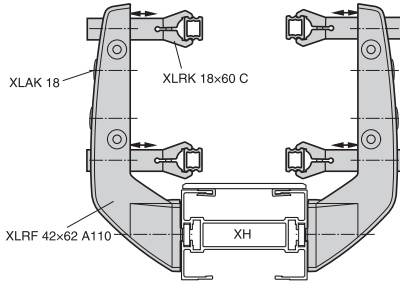

1. Guide rails with XLRF 42x62 A110 2. Guidance of wide & high products

3. Twin-level steel guide rails

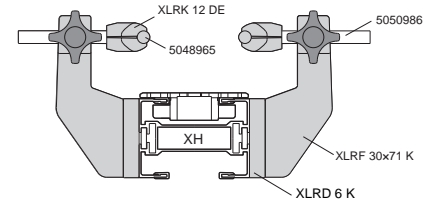
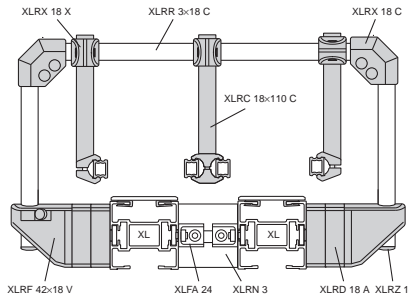
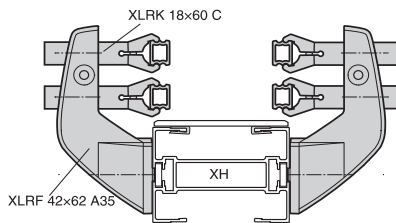

4. Guide rails with XLRF 42x62 A35

5. Double track guide rails

6. Steel guide rails, quick adjustment

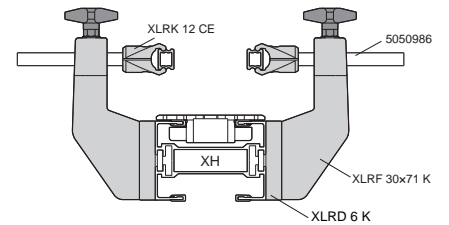
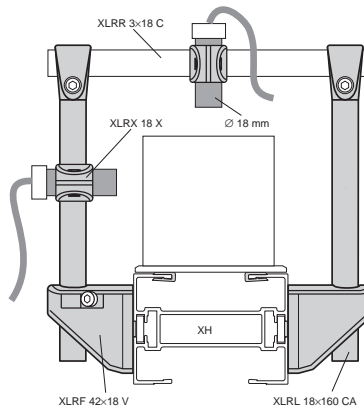
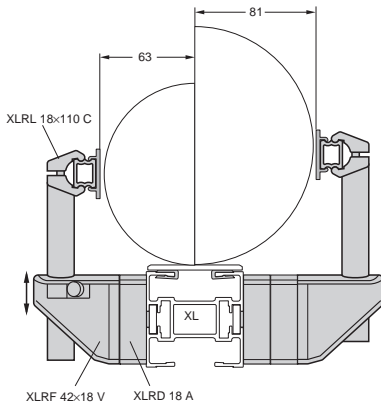

7. Application for tissue paper

8. Attachment of sensors I

9. Plastic/aluminium guide rails, quick adjustment

P0
CC
X45
XS
X65
X65P
X85
X85P
XH
XK
XKP
X180
X300
GR
CS
XT
HU
WL
WK
XC
XF
XD
ELV
CTL
FST
TR
APX
IDX

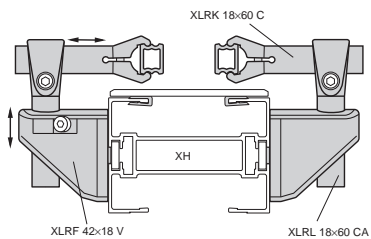

10. Adjustable in width and height

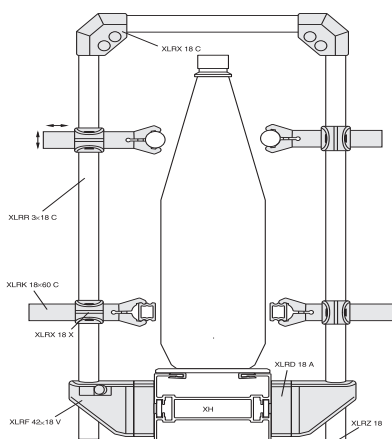

11. Guidance of bottles, etc.

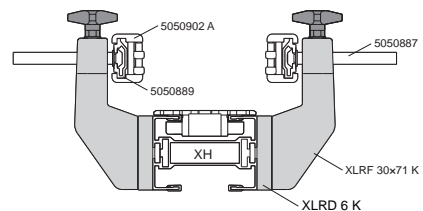

12. Roller module guidance, quick adjustment

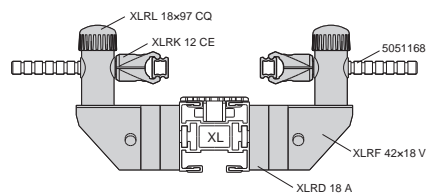

13. Quick-release guide rail brackets

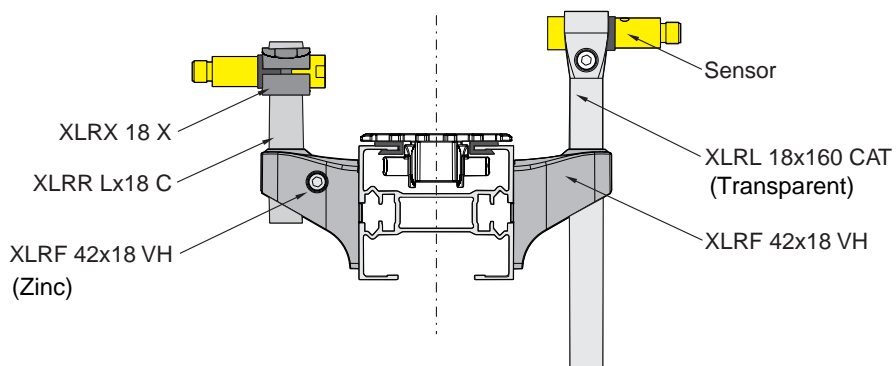

14. Attachment of sensors II

Circular guide rails

PO

Steel rod 12 mm

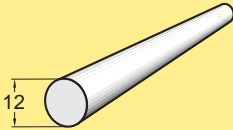

Straight steel rod 12 mm
Stainless steel
Length 3 m

5048965

Aluminium tube 18 mm

Aluminium tube 18 mm
See page 322

XLRR ...x18 C

CC

X45

XS

X65

X65P

Guide rails 10 mm

X85

Guide rail 10 mm, aluminium

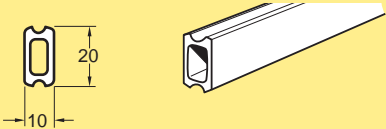

Straight rail 10 mm
Aluminium, length 3 m

XLRS 3x10

X85P

Guide rail 10 mm, aluminium, flanged

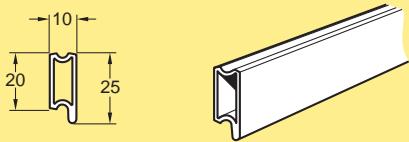

Straight rail 10 mm, flanged
Aluminium, length 3 m

XLRS 3x10 F

XH

XK

XKP

X180

Guide rail 10 mm, steel

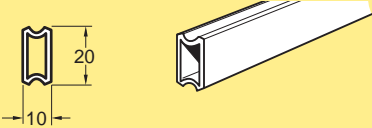

Straight rail 10 mm
Steel, length 3 m

XLRS 3x10 T

Connecting plug 10 mm



Connecting plug 10 mm

XLRJ 10

Note. Not for steel guide rail. Contains 10 pcs.

X300

GR

CS

Guide rail 10 mm, polyethylene

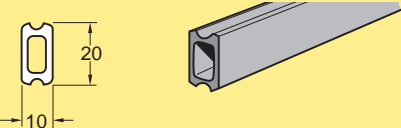

Flexible rail 10 mm
Polyethylene, length 3 m

XLRS 3x10 P

End plug, 10 mm



End plug 10 mm

XLRE 10

Note. Not for steel guide rail. Contains 10 pcs.

XT

HU

WL

WK

XC

XF

XD

ELV

CTL

FST

TR

APX

IDX

Guide rails 15 mm

Guide rail 15 mm, aluminium

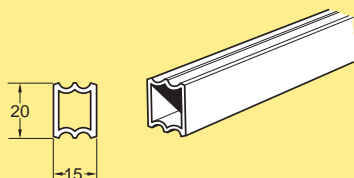

Straight rail 15 mm
Aluminium, length 3 m

XLRS 3x15

Guide rail 15 mm, polyethylene

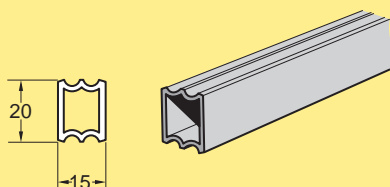

Flexible rail 15 mm
Polyethylene, length 3 m

XLRS 3x15 P

Guide rail cover for 15 mm aluminium guide rail

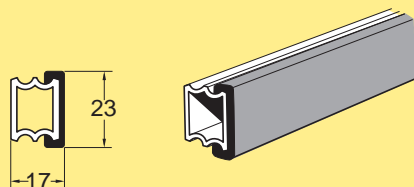

Guide rail cover for 15 mm guide rail
Polyethylene, length 3 m

XLRT 3x23

Guide rail cover for 15 mm guide rail
UHMW-PE, length 3 m

XLRT 3x23 U

Guide rail cover, flanged, for 15 mm aluminium guide rail

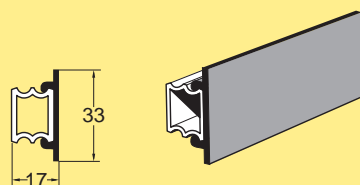

Guide rail cover for 15 mm guide rail
Polyethylene, length 3 m, flanged

XLRT 3x33 D

Connecting plug, 15 mm



Connecting plug 15 mm

XLRJ 15

Note. Contains 10 pcs.

End plug, 15 mm



End plug 15 mm

XLRE 15

Note. Contains 10 pcs.

Flocked tape



Flocked tape

5056398

Width: 20 mm
Length: 12,5 m
Thickness: 0,21+ Flock
Material: PA 6.6

Flocked tape to protect fragile products, could be mounted on e.g. Guide rails

Guide rail bending machine

Guide rail bending machine



Guide rail bending machine

For 10/15 mm aluminium guide rails **3922963**

Height 550 mm, width 360 mm, depth 190 mm
Weight 16 kg
Maximum bend angle 180°
Minimum bend radius 100 mm

Connecting sleeve

Connecting sleeve

Connecting sleeve **XLRJ 100**
 Including set screws. For connecting two 10 mm or 15 mm XLRs guide rails end to end.

Connecting sleeve

Connecting sleeve
 Aluminium, length 3 m **5122544**

Flexible roller module

Flexible roller module

Flexible roller module
 Length 348 mm **5050902 A**
 Mounting to profile 5050889: SK6SS 4x20

Rod for roller module profile

Rod for roller module profile
 Ø12 mm **5050887**
 Mounting to roller module profile 5050889: XCAN 8, BRB 8.4x16.
 For use with guide rail bracket support Type K.

Roller module profile

Roller module profile
 Length 3 m **5050889**
 For use with roller module 5050902 A. Use connecting strip XLCJ 5x140 for joints.

PO
 CC
 X45
 XS
 X65
 X65P
 X85
 X85P
 XH
 XK
 XKP
 X180
 X300
 GR
 CS
 XT
 HU
 WL
 WK
 XC
 XF
 XD
 ELV
 CTL
 FST
 TR
 APX
 IDX

Guide discs

Guide discs are used in place of conventional guide rail for the inner bend of Plain bends/Bend drive units. The guide discs are snap-fitted onto the large discs.

The guide discs correspond to fixed guide rail brackets as shown in the following tables. Other combinations are possible if a non-symmetrical track can be accepted.

Conveyor system XS. Outer guide rail: 10 mm

Track width	Guide rail bracket	Guide disc
56 mm	XLRB 11x30	XLRG 235
80 mm	XLRB 23x30	XLRG 212
104 mm	XLRB 35x30	XLRG 187
130 mm	XLRB 48x30	XLRG 162

Conveyor system X65. Outer guide rail: 10 mm

Track width	Guide rail bracket	Guide disc
67 mm	XLRB 11x30	XLRG 235
90 mm	XLRB 23x30	XLRG 212
115 mm	XLRB 35x30	XLRG 187
140 mm	XLRB 48x30	XLRG 162

Conveyor system X85. Outer guide rail: 15 mm

Track width	Guide rail bracket	Guide disc
87 mm	XLRB 16x42	XLRG 235
110 mm	XLRB 28x42	XLRG 212
135 mm	XLRB 40x42	XLRG 187
160 mm	XLRB 53x42	XLRG 162

Conveyor system XH. Outer guide rail: 15 mm

Track width	Guide rail bracket	Guide disc
107 mm	XLRB 16x42	XLRG 235
130 mm	XLRB 28x42	XLRG 212
155 mm	XLRB 40x42	XLRG 187
180 mm	XLRB 53x42	XLRG 162

Note

Guide discs are not used with conveyor systems XK and X180/X300.

Guide disc for wheel bend

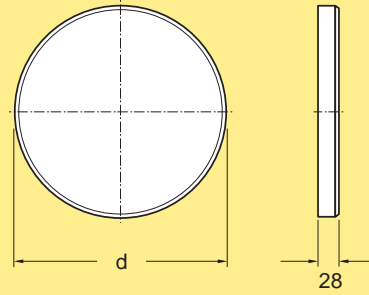

Guide disc for wheel bend

Polyamide
d=230 mm
d=212 mm
d=187 mm
d=162 mm

XLRG 235
XLRG 212
XLRG 187
XLRG 162

Guide disc for bend drive unit

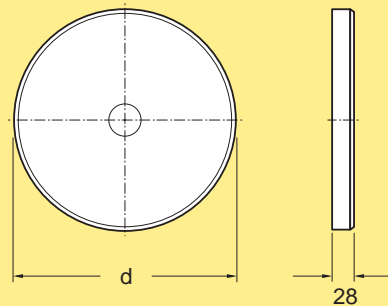

Guide disc for bend drive unit

Polyamide
d=230 mm
d=212 mm
d=187 mm
d=162 mm

XLRG 235 H
XLRG 212 H
XLRG 187 H
XLRG 162 H

Effective track width

Effective track width W (see illustration) for symmetrical tracks with 15 mm guide rail. For 10 mm guide rail: add 10 mm.

Bracket type	XS mm	X65 mm	X85 mm	XH mm	XK mm	X180 mm	X300 mm
XLRB 11x30	47	67	-	-	-	-	-
XLRB 23x30	61	81	-	-	-	-	-
XLRB 35x30	85	105	-	-	-	-	-
XLRB 48x30	111	131	-	-	-	-	-
XLRB 29x36	72	92	-	-	-	-	-
XLRB 16x42	47	67	87	107	-	184	302
XLRB 28x42	71	91	111	131	-	208	326
XLRB 40x42	95	115	135	155	-	232	350
XLRB 49x42	113	133	153	173	-	250	368
XLRB 53x42	121	141	161	181	-	258	376
XLRB 65x42	145	165	185	205	-	282	400
XLRB 90x42	195	215	235	255	-	332	450
XLRB 16x54	-	-	-	-	107	184	302
XLRB 40x54	-	-	-	-	155	232	350
XLRB 65x54	-	-	-	-	205	282	400

10 mm guide rail only

If type XLRB 35x30 is used with angle plate, use 10 mm guide rail.

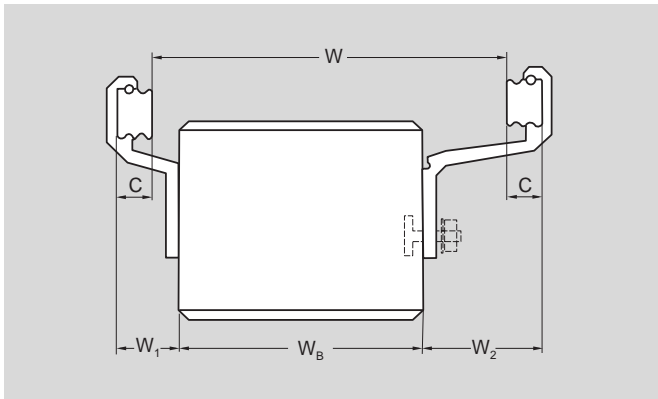

Mounting hardware

Screws, nuts, and washers for mounting of guide rail brackets to the conveyor beam must be ordered separately.

Fixed guide rail bracket, aluminium (XS, X65)

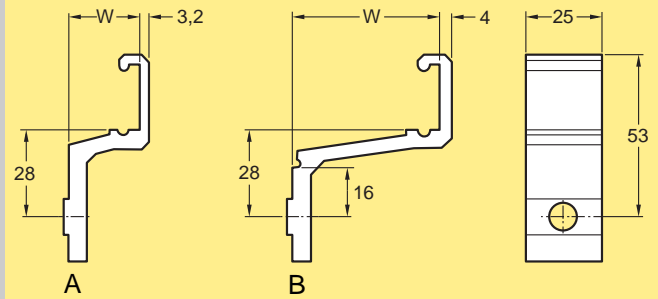

Fixed guide rail bracket

$W=11$ mm Fig. A

$W=23$ mm Fig. A

$W=35$ mm Fig. B

$W=48$ mm Fig. B

XLRB 11x30

XLRB 23x30

XLRB 35x30

XLRB 48x30

Fixed guide rail bracket for X65 pallets

$W=29$ mm

XLRB 29x36

Note. Bracket type B can take angle plates when used with X65 conveyor. Type XLRB 35x30 with angle plate can only be used with 10 mm guide rail.

The XLRB..x30 brackets cannot be used with a guide rail passing through the inner curve of a wheel bend. The guide rail will interfere with the wheel. If possible, use a guide disc.

Mounting to beam: XLAT 17, XLAN 8, BRB 8.4x16.

Fixed guide rail bracket, aluminium (XK, X180/X300)

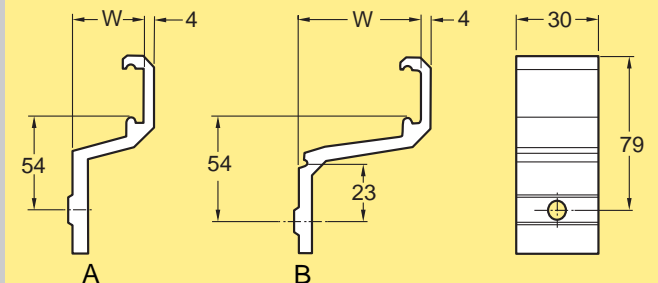

Fixed guide rail bracket

$W=16$ mm Fig. A

$W=40$ mm Fig. B

$W=65$ mm Fig. B

XLRB 16x54

XLRB 40x54

XLRB 65x54

Mounting to beam: XLAT 17, XLAN 8, BRB 8.4x16.

**Fixed guide rail bracket, aluminium
(XS, X65, X85, XH, X180/X300)**

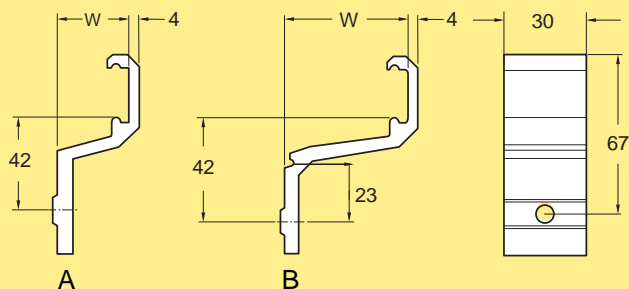

Fixed guide rail bracket

W=16 mm Fig. A	XLRB 16×42
W=28 mm Fig. A	XLRB 28×42
W=40 mm Fig. B	XLRB 40×42
W=49 mm Fig. B	XLRB 49×42
W=53 mm Fig. B	XLRB 53×42
W=65 mm Fig. B	XLRB 65×42
W=90 mm Fig. B	XLRB 90×42

Note. All brackets except 16 mm and 28 mm types can take angle plates when used with X85 and XH conveyor. (XLRB 40×42: angle plate XLRP 3/6 only). Although XLRB ..x42 can be used with X180/X300 conveyors, the resulting height of the guide rail is often insufficient for safe guidance, especially for the wider brackets. Use adjustable polyamide brackets or built-up brackets if type XLRB ..x54 are not suitable.

Mounting to beam: XLAT 17, XLAN 8, BRB 8.4×16.

Distance piece (aluminium)

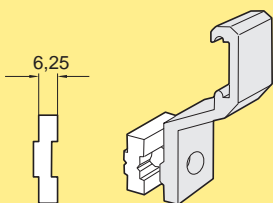

Distance piece (aluminium)
Thickness 6,25 mm

XLRD 6

Not for conveyor system XK (use XLRD 6 C).

Suitable, longer T-bolts: see Fasteners.

Note. Contains 10 pcs.

Distance piece (aluminium) for conveyor system XK

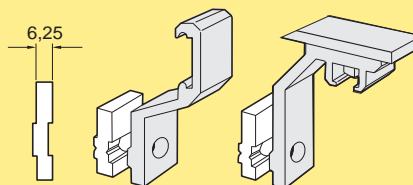

Distance piece (aluminium) for
conveyor system XK

Thickness 6,25 mm

XLRD 6 C

Suitable, longer T-bolts: see Fasteners.

Note. Contains 10 pcs.

Distance piece (polyamide)

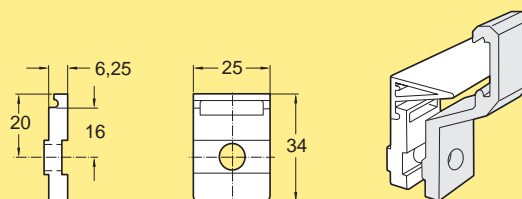

Distance piece (polyamide)

Thickness 6,25 mm

XLRD 6 P

Can hold angle plates (X65 only)

Not for conveyor system XK (use XLRD 6 C).

Suitable, longer T-bolts: see Fasteners.

Note. Contains 10 pcs.

Spring pin for guide rail bracket

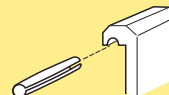

Spring pin for guide rail bracket **XLAP 28**

The spring pins are used to secure the guide rails to the guide rail brackets.

Note. Contains 50 pcs.

Effective track width

Effective track width W (see illustration) with 15 mm guide rail. For 10 mm guide rail: add 10 mm.

Bracket type	XS mm	X65 mm	X85 mm	XH mm
XLRA 8x9x45	16-34	36-54	-	-
XLRA 8x39x45	0-34	0-54	-	-
XLRA 26x9x45	52-70	72-90	-	-
XLRA 26x39x45	0-70	12-90	-	-
XLRA 16x30x52	0-49	9-69	29-89	49-109
XLRA 41x30x52	39-99	59-119	79-139	99-159

Bracket type	XK mm	X180 mm	X300 mm
XLRA 16x30x64	49-109	126-186	246-306
XLRA 41x30x52	-	176-236	296-356

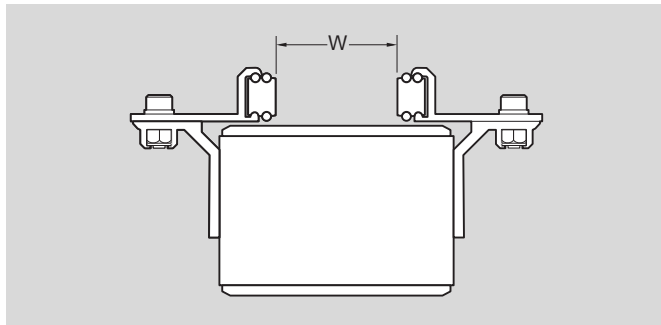

Adjustable guide rail bracket, aluminium (XS, X65)

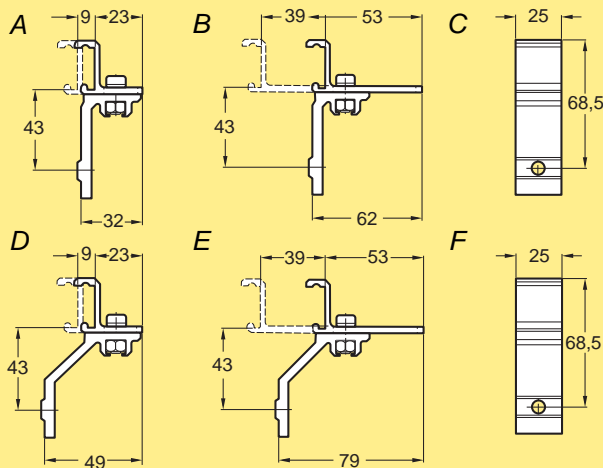

Adjustable guide rail bracket assembly

See Figure A, C **XLRA 8x9x45**
 See Figure B, C **XLRA 8x39x45**
 See Figure D, F **XLRA 26x9x45**
 See Figure E, F **XLRA 26x39x45**

Including bolt and nut
 Mounting to beam: XLAT 17, XLAN 8, BRB 8.4x16.

Adjustable guide rail bracket, aluminium (XS, X65, X85, XH, X180/X300)

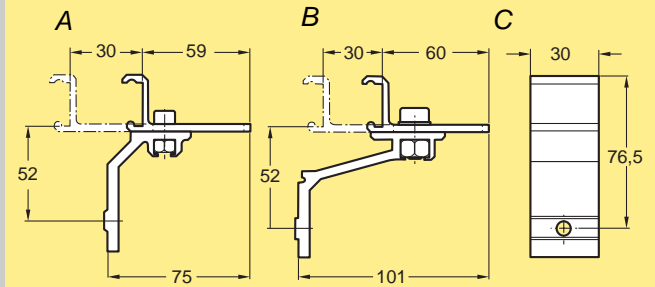

Adjustable guide rail bracket assembly

See Figure A, C
 See Figure B, C

XLRA 16x30x52
XLRA 41x30x52

Including bolt and nut

Note. Bracket type B can take angle plates when used with X85 and XH conveyor.

Mounting to beam: XLAT 17, XLAN 8, BRB 8.4x16.

Adjustable guide rail bracket, aluminium (XK, X180/X300)

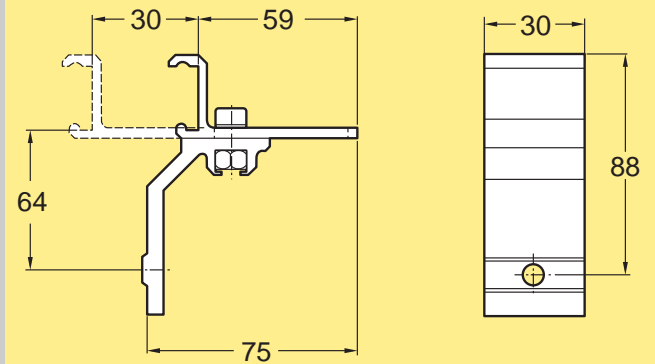

Adjustable guide rail bracket assembly

XLRA 16x30x64

Including bolt and nut

Mounting to beam: XLAT 17, XLAN 8, BRB 8.4x16.

Distance piece (aluminium)

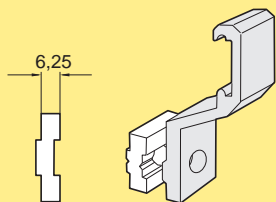

Distance piece (aluminium)
Thickness 6,25 mm

XLRD 6

Not for conveyor system XK (use XLRD 6 C).

Suitable, longer T-bolts: see Fasteners.

Note. Contains 10 pcs.

Distance piece (polyamide)

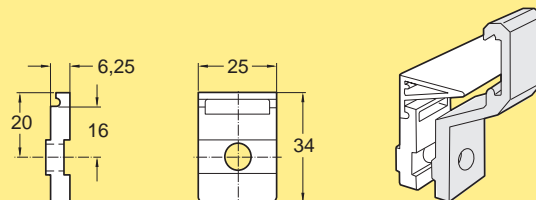

Distance piece (polyamide)
Thickness 6,25 mm

XLRD 6 P

Can hold angle plates (X65 only)

Not for conveyor system XK (use XLRD 6 C).

Suitable, longer T-bolts: see Fasteners.

Note. Contains 10 pcs.

Distance piece (aluminium) for conveyor system XK

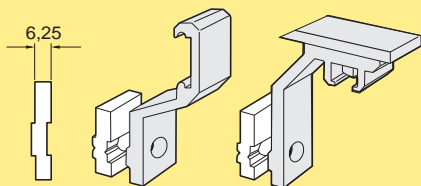

Distance piece (aluminium) for
conveyor system XK
Thickness 6,25 mm

XLRD 6 C

Suitable, longer T-bolts: see Fasteners.

Note. Contains 10 pcs.

Spring pin for guide rail bracket

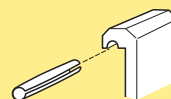

Spring pin for guide rail bracket **XLAP 28**

*The spring pins are used to secure the guide rails to the
guide rail brackets.*

Note. Contains 50 pcs.

Fixed guide rail bracket, polyamide (XS, X65)

Fixed guide rail bracket
Polyamide
XLRB 11x30 C

Can be used with XS and X65 conveyor beam.
Track widths: see table on page 313.
Mounting to beam: XLAT 17, XLAN 8, BRB 8.4x16.
Do not overtighten (max torque: 10 Nm).

Spacer for guide rail bracket, polyamide

Distance piece Type A
Polyamide
D= 6 mm
D= 18 mm

XLRD 6 A
XLRD 18 A

Spacer beams are also available. See page 319.
Note. Contains 10 pcs.

Fixed guide rail bracket, polyamide (XS, X65, X85, XH, X180/X300)

Fixed guide rail bracket
Polyamide
Width 16 mm
Width 40 mm

XLRB 16x42 C
XLRB 40x42 C

Can be used with XS, X65, X85, XH, X180/X300 conveyor beam.
Track widths: see table on page 313.
Mounting to beam: XLAT 17, XLAN 8, BRB 8.4x16
Do not overtighten (max torque: 10 Nm).

Bracket support components, polyamide

Guide rail bracket support Type A35

Guide rail bracket support
XLRF 42x62 A35

To be used with guide rail clamp XLRK 18x40/60/80 C.
For 1–2 guide rail levels. Including screw and nut.
Screw can be replaced by star knob XLAR 6x20
Mounting to beam: XLAT 17, XLAN 8, BRB 8.4x16.
Use socket wrench with 3/8" drive. Do not overtighten (max torque: 10 Nm).
Note. Always install dummy plugs XLAK 18 (page 318) in unused clamp positions to ensure positive locking of the adjacent clamp.

Guide rail bracket support Type A110

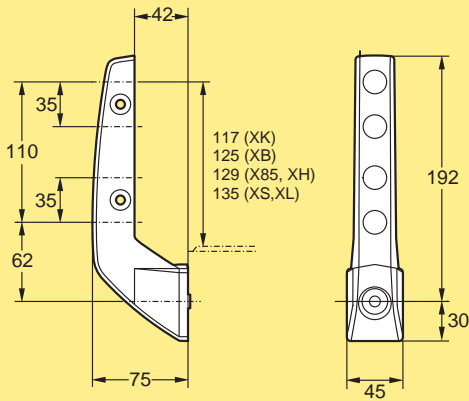

Guide rail bracket support **XLRF 42x62 A110**

To be used with guide rail clamp XLRK 18x40/60/80 C. For 1–4 guide rail levels. Including screw and nut. Screw can be replaced by star knob XLAR 6x20

Mounting to beam: XLAT 17, XLAN 8, BRB 8.4x16 Use socket wrench with 3/8" drive. Do not overtighten (max torque: 10 Nm).

Note. Always install dummy plugs XLAK 18 (page 318) in unused clamp positions to ensure positive locking of the adjacent clamp.

Dummy plug

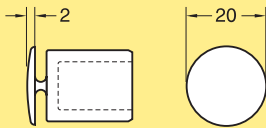

Dummy plug for XLRF 42x62 A35/110

XLAK 18

Note. Contains 10 pcs.

Guide rail bracket support Type V

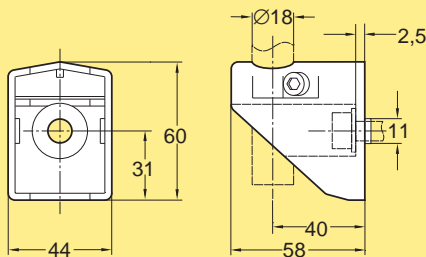

Guide rail bracket support **XLRF 42x18 V**

To be used with vertical 18 mm tube or rod, guide rail clamp XLRL/XLRC 18x110 C, or with quick release clamp XLRL 18x97 CQ.

Mounting to beam: XLAT 17, XLAN 8, BRB 8.4x16 Use socket wrench with 3/8" drive. Do not overtighten (max torque: 10 Nm).

Clamp screw can be replaced by star knob XLAR 6x20

Guide rail bracket support Type VD

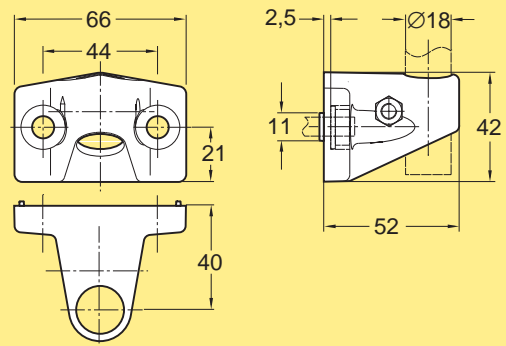

Guide rail bracket support **XLRF 40x18 VD**

To be used with vertical 18 mm tube or rod, or guide rail clamp XLRL/XLRC 18x110 C.

Mounting to beam: 2 each of MC6S 8x14, XLAQ 8, BRB 8.4x16

Guide rail bracket support Type K

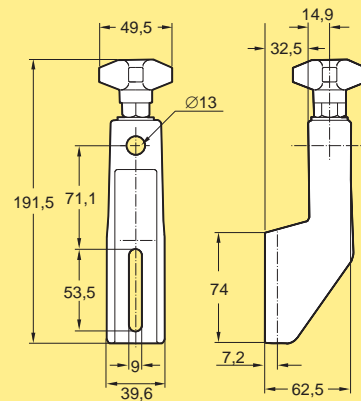

Guide rail bracket support with star knob

XLRF 30x71 K

To be used with guide rail clamps based on 12 mm steel rods, e.g. XLRK 12x100 D69, 5050986, or 5050887 (for roller module).

Mounting to beam: XLAT 17, XLAN 8, BRB 8.4x16

Reinforced Guide rail bracket support Type VH

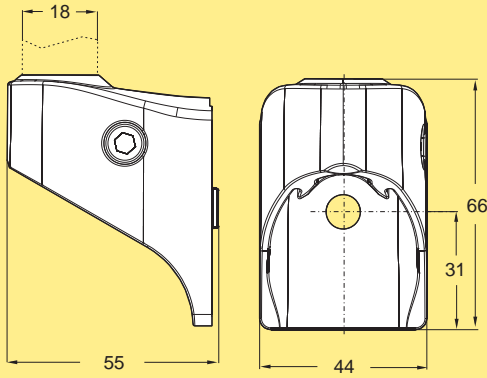

Reinforced Guide rail bracket support, material: Zinc

XLRF 42x18 VH

To be used with vertical 18 mm tube or rod, guide rail clamp XLRL/XLRC 18x110 C, or with quick release clamp XLRL 18x97 CQ.

Mounting to beam: XLAT 17, XLAN 8, BRB 8.4x16
Use socket wrench with 3/8" drive.
Do not overtighten (max torque: 10 Nm).

Spacers

Spacer for guide rail bracket support Type A

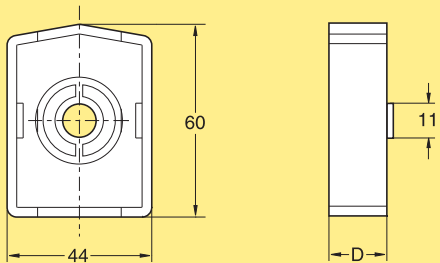

Distance piece Type A

Polyamide

D= 6 mm

D= 18 mm

XLRD 6 A
XLRD 18 A

For use with guide rail bracket supports XLRF 42x...
Note. Contains 10 pcs.

Spacer for guide rail bracket support Type K

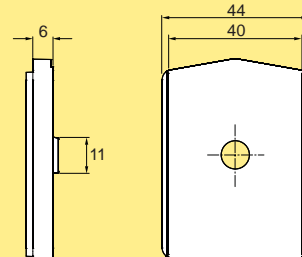

Distance piece Type K

Polyamide

XLRD 6 K

For use with guide rail bracket support XLRF 30x71 K
Note. Contains 10 pcs.

Spacer beam for guide rail bracket support

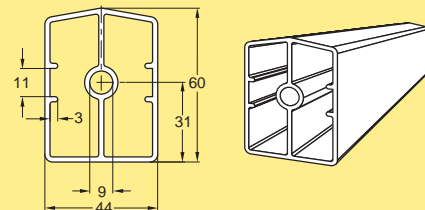

Spacer beam with flat sides

Length 3 m (3030 ±5 mm)

Length to order (30- 3000 mm)

XLRN 3 U
XLRN L U

For use with guide rail bracket supports XLRF 42x...

Mounting: M8 through screw BRB 8.4x16, XLAQ 8, XLRD 3 D

Spacer beam for guide rail bracket support

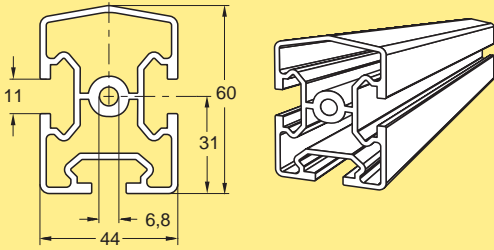

Spacer beam with T-slots
 Length 3 m (3030 ±5 mm) **XLRN 3**
 Length to order (30- 3000 mm) **XLRN L**

For use with guide rail bracket supports XLRF 42x...

Mounting, conveyor beam side: XCFA 44 B (2), XLAT 17 (4), XLAN 8 (4)

Mounting, bracket side: ISO 4762 M8 x16 St 8.8, BRB 8.4x16 (M8 threading of centre hole in beam is required)

Spacer beam connector

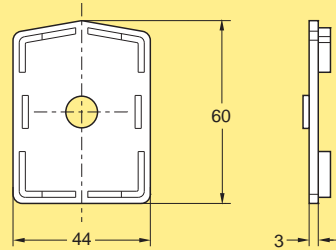

Spacer beam connector **XLRD 3 D**

For use with spacer beam type XLRN 3 U
 Note. Contains 10 pcs.

Guide rail clamp supports

Guide rail clamp support Type CA

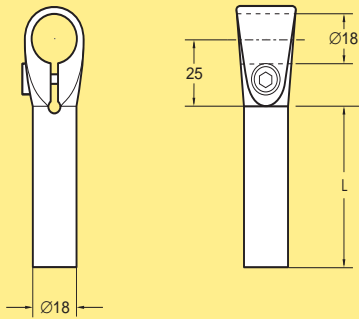

Guide rail clamp support
 L=60 mm **XLRL 18x60 CA**
 L=110 mm **XLRL 18x110 CA**
 L=160 mm **XLRL 18x160 CA**

Including screw and nut. For use with XLRK 18x40/60/80 C

Quick release guide rail clamp support

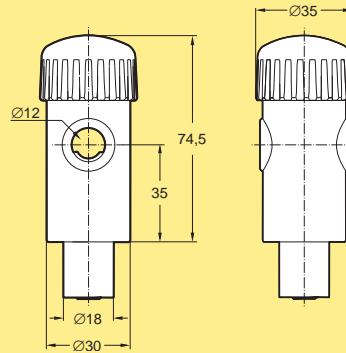

Quick release guide rail clamp support **XLRL 18x97 CQ**

For use with guide rail bracket support XLRF 42x18 V and a 12 mm guide rail clamp rod, e.g. 5051168 (or 5050986 with custom grooves)

Guide rail clamp support Type CAT, Transparent

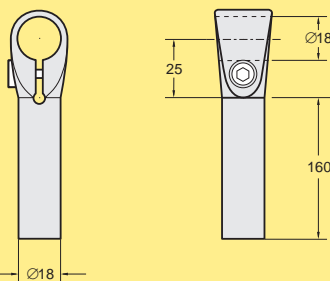

Guide rail clamp support **XLRL 18x160 CAT**
 Material: Plastic

Including screw and nut. For use together with sensor and reflector brackets.

Guide rail clamp 1

Guide rail clamp 1
 L=40 mm
 L=60 mm
 L=80 mm

XLRK 18x40 C
XLRK 18x60 C
XLRK 18x80 C

Including screw and nut
 For use with guide rail bracket supports Type A35/A110, guide rail clamp supports Type CA, or cross connector XLRX 18 X.

Guide rail clamp for double track conveyor

Guide rail clamp for double track conveyor
XLRC 18x110 C

Including screw and nut. Suitable for use with cross connector XLRX 18 X and a crossing 18 mm aluminium tube above the double track.

CC
 X45
 XS
 X65
 X65P
 X85
 X85P
 XH
 XK

Guide rail clamp 2

Guide rail clamp 2
XLRL 18x110 C

Including screw. To be used directly with guide rail bracket supports XLRF 42x18 V or XLRF 40x18 VD.

Guide rail clamp 4

Guide rail clamp 4
XLRK 12 CE

Including screw and nut. For use with 12 mm guide rail clamp rod 5051168 or 5050986. Suitable guide rail types: XLRs ... or 18 mm tube/rod.

XKP
 X180
 X300
 GR

Guide rail clamp 3

Guide rail clamp 3
XLRK 18 CE

Including screw and nut. For use with 18 mm tube XLRR ...x18 C.

Guide rail clamp 5

Guide rail clamp 5
XLRK 12 DE

Including stainless steel screw and nut. For use with 12 mm guide rail clamp rod 5051168 or 5050986. Suitable guide rail type: 12 mm steel rod type 5048965.

CS
 XT
 HU
 WL
 WK
 XC
 XF
 XD
 ELV

Guide rail clamp rod with grooves, 12 mm

Guide rail clamp rod with grooves
 Stainless steel
5051168

For use with guide rail clamps XLRK 12 CE/DE and clamp support XLRL 18x97 CQ.

CTL
 FST
 TR
 APX
 IDX

Guide rail clamp rod, plain, 12 mm

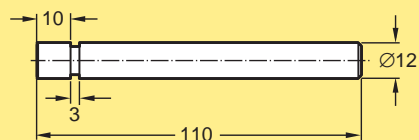

Guide rail clamp rod, plain
Stainless steel

5050986

For use with guide rail clamp XLRK 12 CE/DE and bracket support XLRF 30x71 K.

Guide rail clamp, double

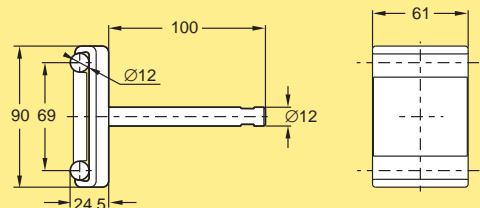

Guide rail clamp, double

XLRK 12x100 D69

Including stainless steel rod, screw and nut. Suitable guide rail type: 12 mm steel rod type 5048965. For use with bracket support XLRF 30x71 K

Accessories

Guide rail support tube, aluminium

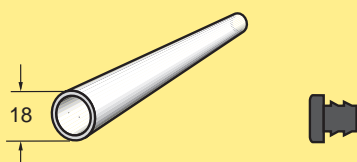

Guide rail support tube
Aluminium

Length 3 m (3030 ±5 mm)

Length to order (30- 3000 mm)

XLRR 3x18 C
XLRR Lx18 C

End cap

XLRZ 18

Note. Contains 10 pcs.

The tube can also be used as guide rail in combination with suitable guide rail clamps.

Cross connector

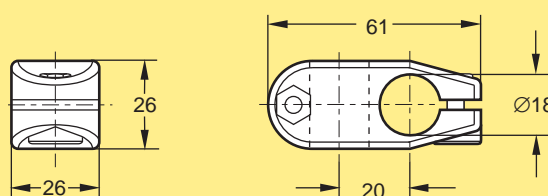

Cross connector

XLRX 18 X

Including screws and nuts. For use with 18 mm aluminium tube type XLRR ..x 18 C and/or guide rail clamps XLRL/XLRC 18x110 C.

Can be used with star knob XLAR 6x20 for easy re-adjustment

Corner connector

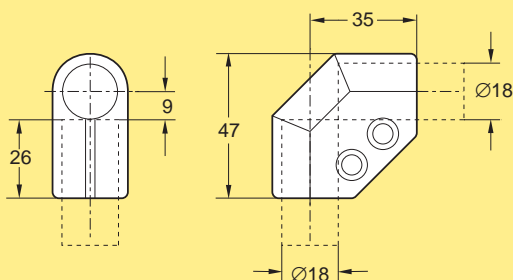

Corner connector

XLRX 18 C

Including screws and nuts. For use with 18 mm aluminium tube type XLRR ..x 18 C.

Star knob

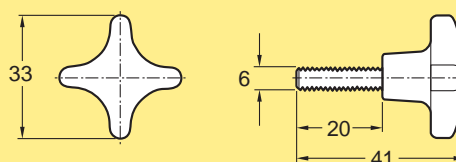

Star knob
M6

XLAR 6x20

Note. Contains 10 pcs.

To be used with XLRF 42x18 V, XLRF 42x62 A35/110, and XLRX 18 X.



Width adjustment

Width adjustment XURA 30x41x37 and XLRA 30x41x50 A

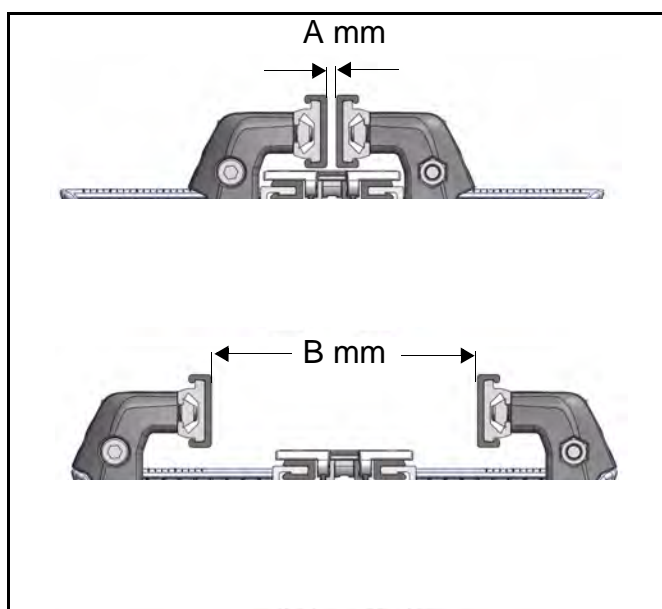

When using XURA 30x41x37 the minimum A width is 2 mm and the maximum B width is 84 mm

When using XLRA 30x41x50 A the minimum A width is 34 mm and the maximum B width is 104 mm

Width adjustment XURA 40x41x37 and XLRA 40x41x50 A

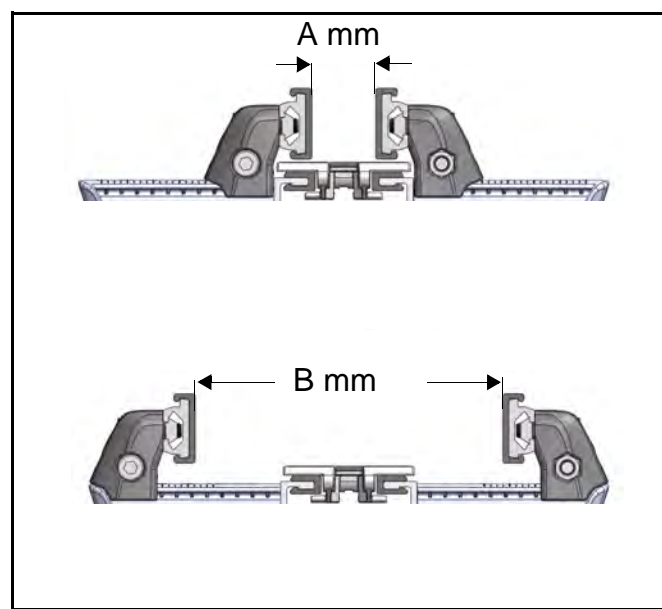

When using XURA 40x41x37 the minimum A width is 20 mm and the maximum B width is 102 mm

When using XLRA 40x41x50 A the minimum A width is 50 mm and the maximum B width is 120 mm

Width scale



The guide rail bracket has an adjustment scale which can be used as a reference when adjusting the guide rails to correct width

Using Guide rail cover

Guide rail cover XLRT 3x23, XLRT 3x23E

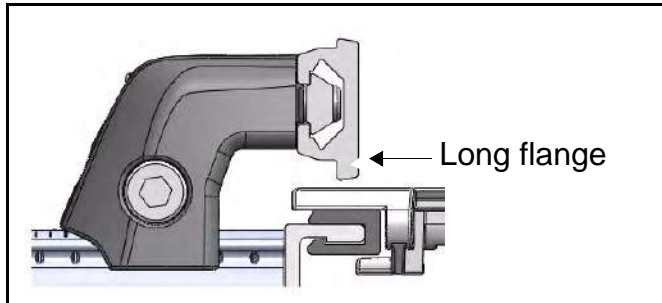
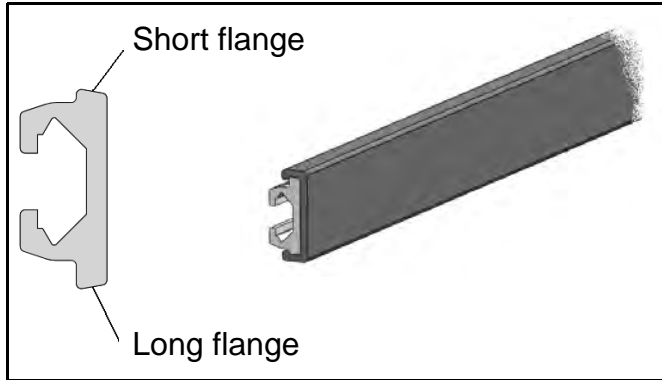

When not using the Guide rail cover the guide rail can be orientated with the long flange down

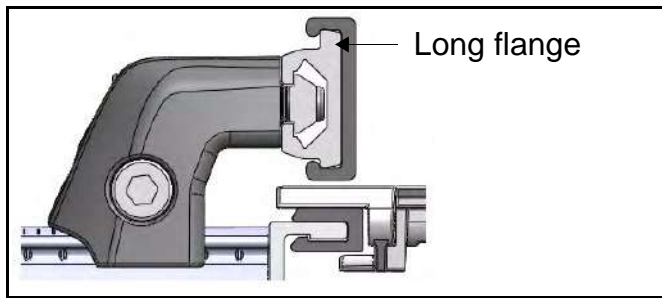

When using the Guide rail cover the rail is to be orientated with the long flange up

Straight guide rails

Guide rail, aluminium

Guide rail
Length 3 m
XURS 3x8
T-slot for XDAN T-slot nuts

End plug

End plug
Contains 10 pcs. pair
XURE 8

Guide rail cover

Guide rail cover
Polyethylene, length 3 m
XLRT 3x23
Guide rail cover
PE-UHMW, (conductive) length 3 m
XLRT 3x23 E

T-slot nut

T-slot nut
Steel, zinc-chromated
M5 Contains 10 pcs
XDAN 5 A

Connecting strips

Connecting strip for guide rail

Beam A
Beam B

Connecting strip, straight
Including set screws
Steel, electro-zinc-plated
XDFC 9x40

Guide rail bracket for X45

Guide rail bracket

Guide rail bracket for X45 **XURA 30x41x37**
Including mounting hardware

Guide rail bracket

Guide rail bracket for X45 **XURA 40x41x37**
Including mounting hardware

Guide rail bracket for X65 and X45H

Guide rail bracket

Guide rail bracket for X 65 and X45H **XLRA 30x41x50 A**
Including mounting hardware

Guide rail bracket

Guide rail bracket for X65 and X45H **XLRA 40x41x50 A**
Including mounting hardware

- PO
- CC
- X45
- XS
- X65
- X65P
- X85
- X85P
- XH
- XK
- XKP
- X180
- X300
- GR**
- CS
- XT
- HU
- WL
- WK
- XC
- XF
- XD
- ELV
- CTL
- FST
- TR
- APX
- IDX

Built-up guide rail brackets

Small beam 24x34

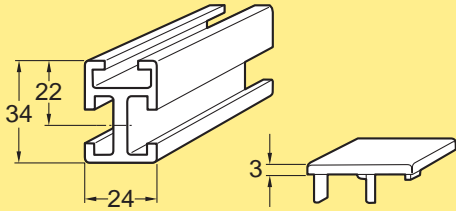

Beam 24 mm x 34 mm
 Length 3 m (3030 ±5 mm) **XCBB 3x24x34**
 Length to order (30- 3000 mm) **XCBB Lx24x34**
 End cap for XCBB 3x24x34 **XCBE 24x34**

Inner fitting 90°

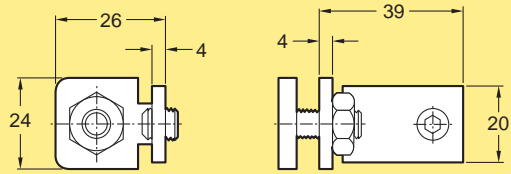

Inner fitting 90° **XMRX 20**
 Including T-bolt, nut, set screw
 Note. Contains 10 pcs.

Small beam 24x44

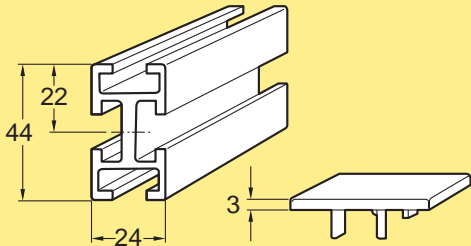

Beam 24 mm x 44 mm
 Length 3 m (3030 ±5 mm) **XCBB 3x24x44**
 Length to order (30- 3000 mm) **XCBB Lx24x44**
 End cap for XCBB 3x24x44 **XCBE 24x44**

Inner fitting 90°

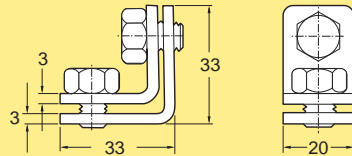

Inner fitting 90° **XMYR 20**
 Including screws
 Note. Contains 10 pcs.

Corner fitting 90°

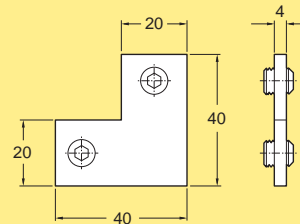

Corner fitting 90° **XMRW 20**
 Including set screws
 Note. Contains 10 pcs.

Guide rail bracket

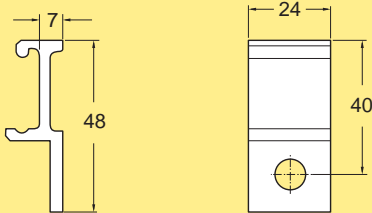

Guide rail bracket **XLRC 20**

Guide rail bracket

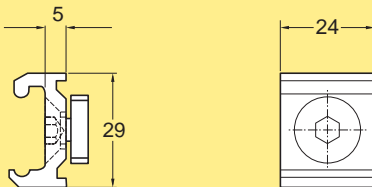

Guide rail bracket **XLRC 20 A**
 Including M8 screw and square nut

Spring pin for guide rail bracket

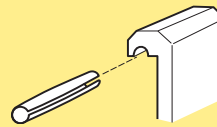

Spring pin for guide rail bracket **XLAP 28**
 Note. Contains 50 pcs.



The automatic adjustable guiding system provides a very flexible way to add width adjustment for conveyors in a production line. The system offers easy automatic resetting of product guiding systems in production flows. The effect is increased line efficiency and safe product distribution throughout the line.

The system has a modular design and consists of guide units for the guiding, control boxes for the control of the guide units and junction boxes for power supply. The system can be linked to the line control system and one control box can control up to 132 or 220 guide units.

Standard features

- Automatic resetting for different product sizes
- Easy to install and expand
- Easy to integrate with existing installations
- Safe
- Each unit is self-driven with high accuracy
- Available in versions with or without position feedback.

Standard products

A system includes the following standard products:

- Guide units (standard or feedback type, basic or heavy version)
- Guide rail components
- Control box (Type 1/2/2b)
- Junction box

Guide unit (GU)

The guide unit has a built-in gear motor that adjusts the guide rails in and out by means of a rotating threaded shaft. The 24 V AC motor provides high enough force for width adjustment but still low enough force to stop if something gets jammed.

Each guide unit includes a cable that is daisy chained to the next guide unit. The synchronous AC motors ensure that the guide units move in parallel.

The feedback version (suffix F) has two sensors, one at the outer position for resetting, and one which counts pulses as the threaded shaft rotates, to indicate the current position. Cables from the sensors are connected to the fieldbus module in the control box.

System reset is done by running the guide units until all guide rails are in the maximum width position.

Basic GU version

The basic version is designed to be positioned above the conveyor track. It comes with $\varnothing 12$ mm vertical bars in two lengths: 196 mm and 296 mm and includes a 2 m GU cable. Recommended distance between guide units is 1 m. Using standard FlexLink's guide rail components, it is possible to get two guide rail configurations: A and B:

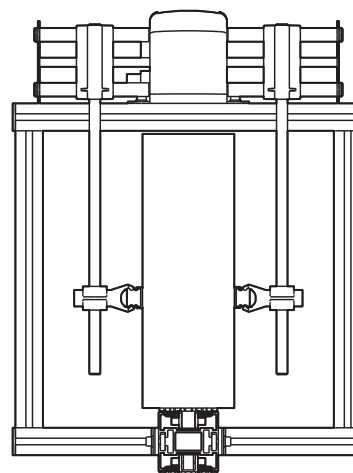

Configuration A

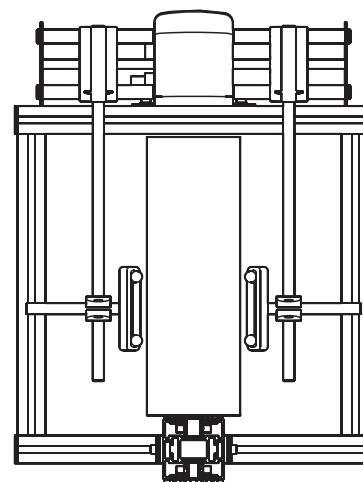

Configuration B

CC
X45
XS
X65
X65P
X85
X85P
XH
XK
XKP
X180
X300
GR
CS
XT
HU
WL
WK
XC
XF
XD
ELV
CTL
FST
TR
APX
IDX

Control system

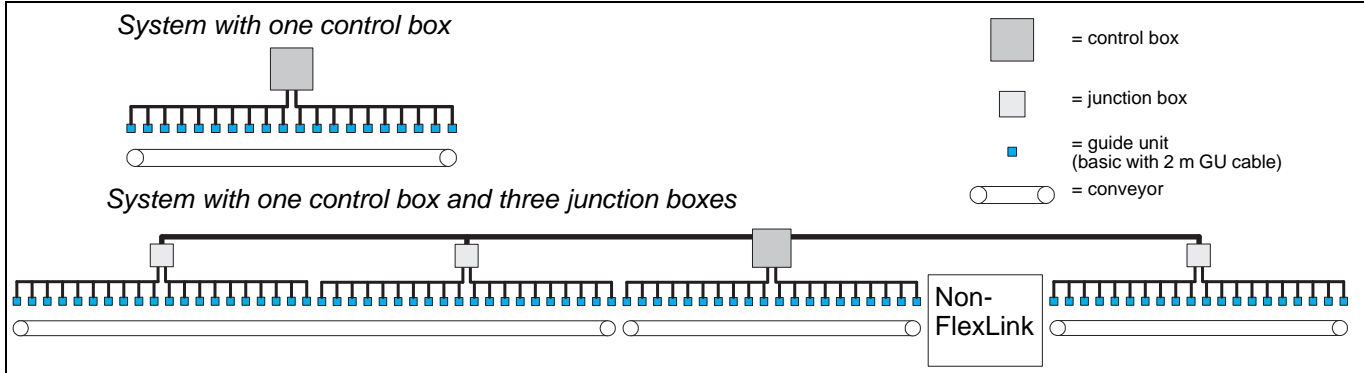

Control box

- The basic control box, Type 1, for manual setting has a switch with three positions: IN/0/OUT.
- The advanced control box, Type 2, automatic setting, has a built-in fieldbus module, which receives control signals from the conveyor system's PLC.
- Control box Type 2b has provisions for installing customer specified communications, such as any preferred type of fieldbus module, or hardwired communications.

In a small system, one Type 1 or Type 2 control box controls a GU group. A larger system can be built by adding junction boxes. Each additional GU group needs a junction box. Systems larger than this require an extra control box.

Position feedback system

The track width can be easily controlled from an operator panel if a control box Type 2 is used in combination with a GU made for position feedback (see *Guide unit* above). Only one such GU is required in a line.

Junction box

In addition to one GU group, a control box can have a maximum of 10 junction boxes (5 in each direction). Each junction box can control one GU group. A group of basic guide units can include up to 20 guide units, whereas a heavy GU group can include maximum 12 guide units. This means a total of 220 basic guide units.

Guide unit

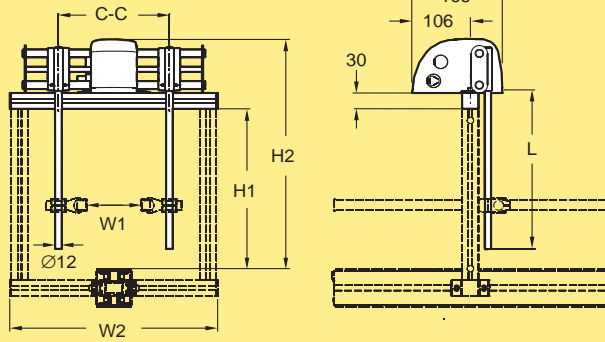

Guide unit, including horizontal beam XFBM 30, no feedback

- Guide unit 284x196 C **XLRQ 284x196 C**
- Guide unit 455x196 C **XLRQ 455x196 C**
- Guide unit 284x296 C **XLRQ 284x296 C**
- Guide unit 455x296 C **XLRQ 455x296 C**

Guide unit, including horizontal beam XFBM 30, with position feedback

- Guide unit 284x196 CF **XLRQ 284x196 CF**
- Guide unit 455x196 CF **XLRQ 455x196 CF**
- Guide unit 284x296 CF **XLRQ 284x296 CF**
- Guide unit 455x296 CF **XLRQ 455x296 CF**

Item	H1	H2	W1	W2	C-C (max.)	L
XLRQ 284x196 ..	165	295	35-190	377	284	196
XLRQ 455x196 ..	165	295	35-360	548	455	196
XLRQ 284x296 ..	265	395	35-190	377	284	296
XLRQ 455x296 ..	265	395	35-360	548	455	296

Includes a 2 m GU cable. Feedback version (suffix BF) includes the necessary sensors.

Distance piece

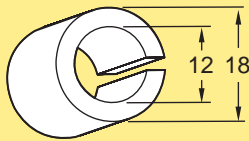

Distance piece **5055818**

Adapter for fitting cross connectors or guide rail clamps to the Ø12 mm vertical bars of the guide units.

Extra GU cable

- Cable, 2 m **5057678**
- Cable, 3 m **5057691**

Additional components

Components required for both configurations A&B (page 327):

Item	Designation	Qty
Washer M6	BRB 6.4x12	4
Beam 30x30 mm	XFBM Lx30	720-1160 mm
End cap	XFBE 30	4
Fastener yoke	XFAF 30	4
Mounting plate	XFFB 30	2
Screw	MF6S 6x30	2
Screw	MC6S 6x14	4
Square nut	XLAQ 6	4
Cross connector	XLRX 18 X	2-4
Distance piece (see above)	5055818	2-4

Additional components required for configuration A (page 327)

Item	Designation	Qty
Guide rail clamp	XLRK 18x40 C	2-4

Additional components required for configuration B (page 327)

Item	Designation	Qty
Guide rail clamp, double	XLRKX 18x50 D69	2

Compatibility with previous GU models

Due to a speed difference, GU types XLRQ ... B/XLRQ ... BF should not be mixed with the previous types without B in the suffix in a line controlled by a common control unit.

Control box

Control box
 Type 1, manual setting, 50 Hz **5113439**
 Type 2, automatic (Profibus), 50 Hz **5113440**
 Type 2, automatic (DeviceNet), 60 Hz **5057420**
 Type 2b, automatic, 50 Hz **5113449**

Junction box

Junction box, 50 Hz **5113441**
 Junction box, 60 Hz **5057479**

Customer specified communications

Guide rails in bends

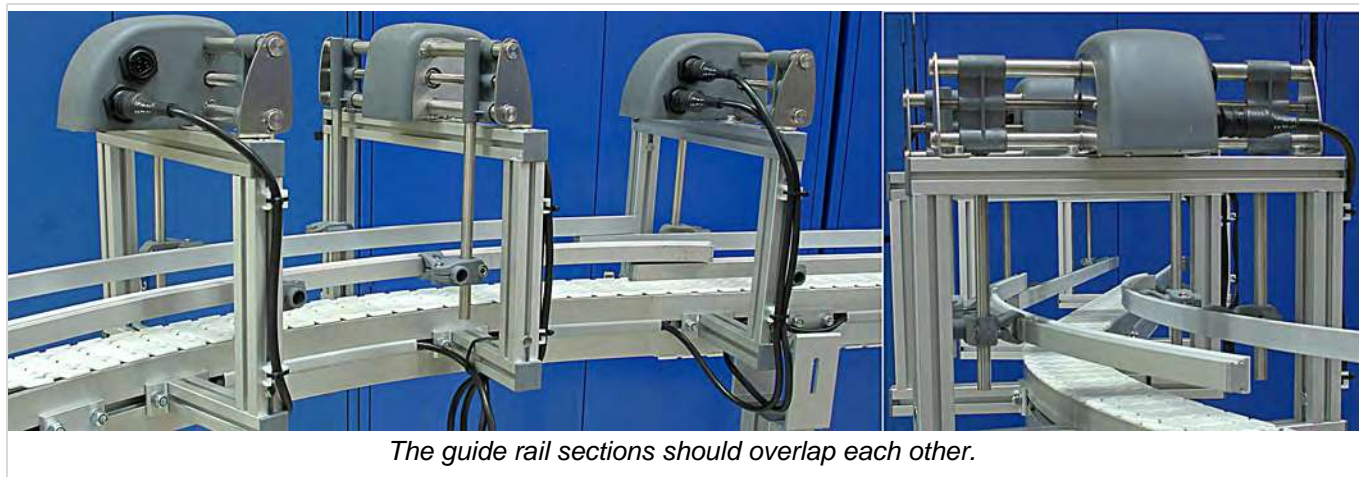

Example: 90° plain bend:

The guide rail is divided into 45° segments. Two guide units are used for each 45° segment. These guide units must be mounted in parallel.

The mid-point of each segment (P) will move with the same accuracy as the straight guide rail sections. If higher accuracy is needed, a 90° bend can be divided into three 30° sections.

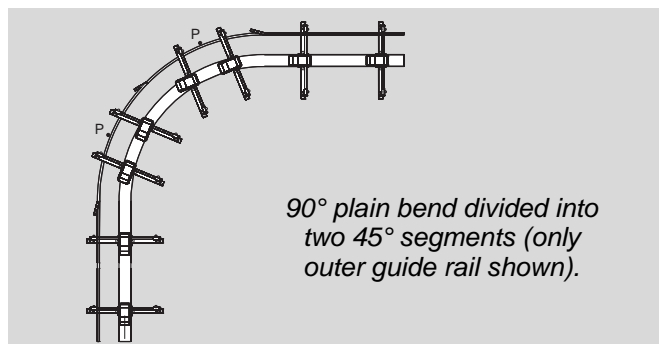

More information

Please contact FlexLink Systems for design assistance. See www.flexlink.com for detailed documentation and CAD files.